

E AÇI ve HAREKET ANALİZİ
ANGLE and MOTION ANALYSIS

MODEL	α [$\pm 2^\circ$]	β [$\pm 2^\circ$]	A	M	AĞIRLIK KG (weight)
1101 Y-L	95	58	14	M5x34	0.16
1102 Y-L	102	56	27,5	M6x53	0.25
1103 Y-L	107	58	26	M8x60	0.5
1104 Y-L	130	68	34	M10x76	0.8
1105 Y-L	135	70	34	M10x76	0.95
1106 Y-L	134	64	35,5	M12x86	1.71

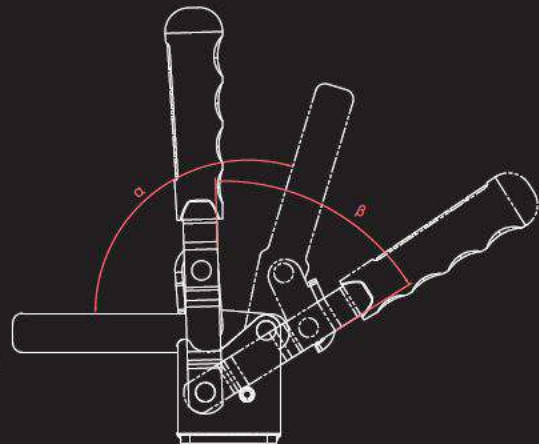

E KUVVET ANALİZİ
FORCE ANALYSIS

MODEL NO	X	X1	X2	Y	FT1 (N)	FT2 (N)	FBI (N)	FB2 (N)	FBI : FU	FB2 : FU
1101 Y-L	29	38	56	92	745	460	575	375	10:1	5:1
1102 Y-L	36	44	71	121	1050	730	800	550	12:1	8:1
1103 Y-L	43	55	100	169	2500	1575	2100	1450	12:1	8:1
1104 Y-L	51	67	143	195	3300	2200	2900	1900	12:1	8:1
1105 Y-L	57,5	97	175	216	4500	2600	4300	2200	12:1	8:1
1106 Y-L	71,5	83,5	106	240	5050	3050	4600	2550	12:1	8:1

FT1-FT2: TUTMA KAPASİTESİ (HOLDING CAPACITY), FBI-FB2: BASKI KUVVETİ (CLAMPING FORCE), FU: UYGULAMA KUVVETİ (APPLIED FORCE)

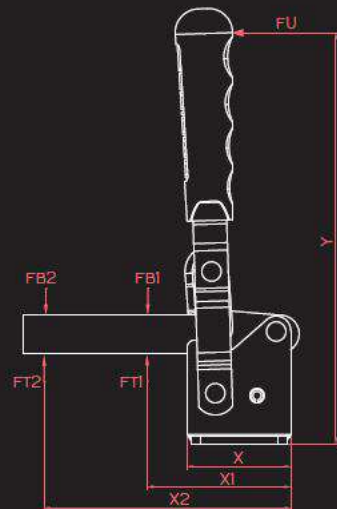

Boyutlar ve teknik bilgiler önceden bildirmeksizin değiştirilebilir.
Dimensions and technical information are subject to change without notice